



Asset Management Solutions

HART® Communicator

- *Connect to any HART® instrument with the HART Communicator—the only communicator you'll need.*
- *Store over 100 device configurations in just one HART Communicator—ready to carry to the field.*
- *Hook it up and turn it on—that's how easy it is to use the HART Communicator.*
- *Program the Hot Key for fast access to routine tasks.*



Figure 1. Plant maintenance is faster when over 100 configurations can be carried directly to the field.

Introduction

What would you say if you could carry the information for more than 100 HART® compatible field devices in the palm of your hand? You can with the HART Communicator. The HART Communicator, with one Fisher-Rosemount data pack 100, empowers you to increase productivity, reduce trips to the field, and gather the kind of data you need to reduce process downtime.

How about using the HART Communicator? Is it easy to use? How long does it take to learn? Can you customize the screen to your specific needs? Yes, it's easy, fast to learn, and you can customize the Hot Key for your most frequent tasks. In fact, when you connect the HART

Communicator to a HART device, the tag and model number of the connected device is automatically displayed on the top line of the LCD screen!

The standard HART Communicator, with 12 MB of memory, contains the device descriptions for all HART devices, regardless of manufacturer. It also holds up to 10 configurations. But 10 configurations is often not enough to meet your day to day requirements. The Fisher-Rosemount data pack 100 was designed to meet this need. The Fisher-Rosemount data pack 100 plugs easily into the memory module to add enough memory for up to an additional 100 configurations. The data pack 100 may be removed and kept as a permanent historical record of instrument activity.

Whether you are taking information from the field, back to the shop, or from the shop to the device, you have the information you need.

The HART Communicator is also a data input device for your plant database. With Asset Management Solutions (AMS) software, you can move information from your HART Communicator directly to your PC. The combination of the HART Communicator and a PC equipped with AMS software gives you an instrument database that enables you to more efficiently and effectively manage the instrument assets that are the foundation of your process.



The **only** device you'll ever need to get information from your HART instruments. The Model 275 HART Communicator has device descriptions built-in for all of the devices in the market today that are HART capable. Period. No matter who makes the device, the HART Communicator can "talk smart"! That means you can reduce your investment in communicators because the HART Communicator takes care of all of your needs. Every maintenance person needs a HART Communicator. It's an investment in productivity.

Start here....



Increase productivity with the ability to carry over 100 device configurations to the field. The Model 275 HART Communicator has the ability to hold up to 10 configurations in the Memory Module. But you told us

you needed more. You needed a way to increase the productivity of your maintenance staff so the number of trips to the field could be reduced. That is why we introduced the Fisher-Rosemount data pack 100. This compact data storage device plugs into the Memory Module and allows up to an additional 100 configurations to be carried with the HART Communicator. That means that one maintenance person can carry the data for more than 100 field device configurations into the field!

get it ready....



The data pack 100 is totally modular and self-contained. You can easily exchange

Streamline regulatory documentation preparation through access to historic configuration and as found/as left data. It often takes longer to document what is found in the field than it takes to make a change in the device.

Combine the convenience of the portable handheld

download it....

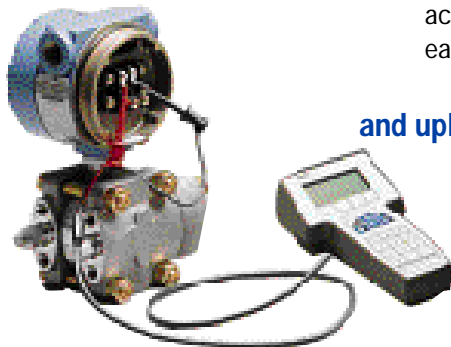

data packs so that you have a permanent, quickly accessible historical record of all of the data for each device in the field.

with the power of AMS. Use your HART Communicator to upload and download information to and from all of your HART devices. Use your Asset Management Solutions software to simply upload device information from your HART Communicator to your PC. You no longer have to dig in file cabinet after file cabinet for device information. All of the information you need to satisfy regulatory requirements is at your fingertips, from anywhere in the plant! Any PC in the plant equipped with AMS can call up information about any smart device in the plant. That's field power. That's efficiency. And most of all, that's ease of use.

and upload it....

to your plant network



Product Information

User Interface

A keypad, liquid crystal display (LCD), and software menu structure make up the HART Communicator user interface. Just press a few buttons to become familiar with the Action Keys and menu structure, and you begin to access all of the functions of your HART devices.



Figure 2. The HART Communicator provides features that make the communicator fast to learn and easy to use.

LCD

The LCD is an eight-line by twenty-one character display that provides a window to all the functions of a HART compatible device. When connected to a HART device, the top line of each menu displays the model name of the device and its tag. The bottom line of each menu is reserved for a dynamic label for each function key, F1 through F4. See Figure 3.

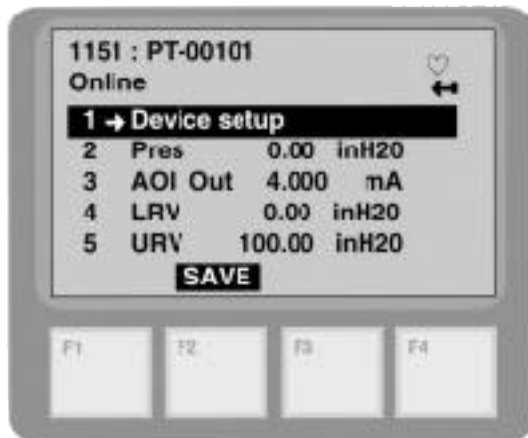

Figure 3. The Online menu along with the Function Keys.

Function Keys

Use the four function keys, marked F1 through F4, located below the LCD to perform software functions as indicated by the dynamic labels. Different labels appear over the four function keys as you move among the various menus. For example, the label **SAVE** appears above the F2 key when device information can be saved, and the label **HELP** appears above the F1 key when access to online help is available. See Figure 3.

Online Menu

When connected to a HART compatible device, simply press the On Key to display the online menu. This menu normally contains the most critical information about the connected device and your measurement, including:

- User-defined Tag
- Actual Input (process variable)
- Actual Analog Output
- Lower Range Value (LRV)
- Upper Range Value (URV)

Action Keys

Six Action Keys promote easy navigation through the menu structure. See Figure 4.

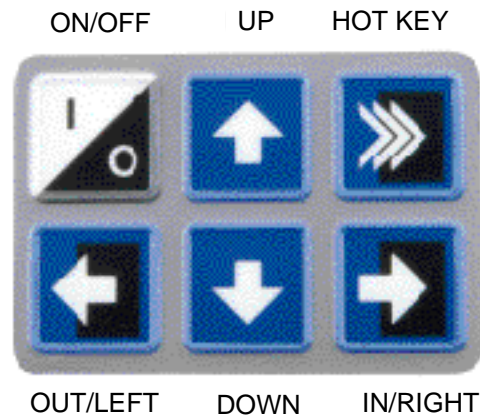

Figure 4. Action Keys.

Hot Key

Customize the Hot Key to quickly access a menu of your most frequently performed online tasks. The Hot Key Menu is a user-definable menu containing one permanent option, Range Values. Range Values provides quick access to rerange capability. Up to 19 of your frequently performed tasks can also be added to this menu. These tasks, stored even when the communicator is off, are always readily available by simply pressing the Hot Key.

Simulation Mode

The HART Communicator provides a mode that allows you to simulate an online connection to a specific HART compatible device. The simulation mode is a training tool that enables you to become familiar with a device before configuring it in a critical environment. Access the simulation mode through the Utility Menu.

Save

Save allows you to quickly store the current configuration data under the current Tag, Descriptor, or Name by pressing the F2 key when **SAVE** appears as a dynamic label. Save As lets the user store configuration data under a user-specified Name Location (Memory Module or Fisher-Rosemount data pack 100) and Data Type (Standard, Partial or Full). Data may be stored in the Memory Module or in the removable data pack as a portable, nonvolatile file.

Data Type

The HART Communicator allows you to specify which variables to save under the current configuration. The three choices are:

- *Standard*—The set of all editable variables defining a new device configuration.
- *Partial*—The set of all marked device variables.
- *Full*—The set of all variables.

Note: It is necessary to save a full configuration if the data is to be transferred to AMS.

Polling

The HART protocol allows for the connection of multiple HART devices on a single twisted pair of wires, or over leased telephone lines. This concept is known as "multidropping". A single HART Communicator can interface with multiple devices on one transmission line. Communication between a host and a multidropped device takes place digitally, with the analog output fixed. In a multidrop installation, each device is identified by a unique address (1-15). Use the Auto Poll option to direct the HART Communicator to search for a connected device at an address other than zero. When Auto Polling is on, the communicator finds every device in the loop and lists them by tag.

Hazardous Locations Certifications

The HART Communicator meets the Intrinsic Safety requirements of the listed regulatory agencies. Selecting one of the Hazardous Locations Certification options provides for the required labeling and information on the HART Communicator

The approval options currently offered include:

- (BASEEFA)/CENELEC - Intrinsic Safety Certification



- Factory Mutual (FM) - Intrinsic Safety Approval



- Canadian Standards Association (CSA) - Intrinsic Safety Approval



Memory Module

The Memory Module is programmed with the operating system software and the application software for a desired set of HART compatible devices. This allows you to easily expand the capability of your HART Communicator as new field devices and product enhancements become available. The Memory Module also stores device configuration data for up to 10 HART compatible devices.



Memory Module

Fisher-Rosemount data pack 100

Fisher-Rosemount data pack 100

The data pack 100 allows the user to store up to 100 device configurations in removable, nonvolatile memory. Users can easily store configuration data for all their HART devices on a small number of data packs. Each data pack easily fits in the palm of your hand or shirt pocket. The data pack is installed at the top end of the memory module and can be simply accessed by removing the battery pack.

Specifications

Memory

Program (and Device Descriptions):
12 MB (standard).

Program (and Device Descriptions):
4 MB (optional).

Transmitter data (standard): 2 KB.

Transmitter data (optional data pack 100): 32 KB removable nonvolatile memory.

Battery Pack Option

Battery holder for 5 disposable AA 1.5 V batteries.

Rechargeable Ni-Cad battery pack.

Recharger Service and Plug Type

110/120 VAC, 50/60 Hz, U.S. plug.
220/230 VAC, European plug.
220/230 VAC, U.K. plug.

Microprocessors

32-bit Motorola type 68331.
8-bit Motorola type 68HC705.

Connections

Leadset: Two 4 mm banana plugs.
Battery Charger: 2.1 mm coaxial power connector (optional).
Serial port: 9-pin D-subminiature socket.
Memory Module: 26-pin, 2-row, 0.1 inch pitch connector.

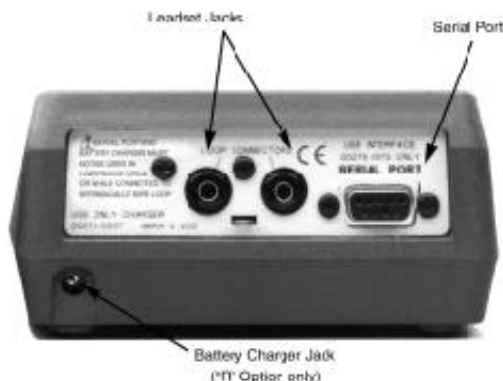

Performance Specifications

Operating Limits

32 to 122° F (0 to 50° C).

Storage Limits

-4 to 158° F (-20 to 70° C).

Humidity Limits

Operates in 0-95% relative humidity under noncondensing conditions over the entire operating range of 32 to 122 oF (0 to 50° C).

Hazardous Locations Certification

British Approvals Service for Electrical Equipment in Flammable Atmospheres (BASEEFA/CENELEC) Intrinsic Safety Certification:

I1 EEx ia IIC T4 (Tamb = 50° C) Certificate No. EX 92C2516

Factory Mutual (FM) - Intrinsic Safety Approval:

I5 Intrinsically Safe for Class I, Division 1, Groups A, B, C, and D;
Non- Incendive for Class I, Division 2, Groups A, B, C, and D.

Canadian Standards Association (CSA) - Intrinsic Safety Approval

I6 Class 2258 03; Process Control Equipment - Intrinsically Safe and Non-Incendive Systems; For Hazardous Locations. Products Class I, Groups A, B, C and D.

Electromagnetic Compatibility (EMC)

**EMC compliant only when the CE logo appears on both the keypad assembly and Memory Module.*

EN50081-1:1992

EN50082-1:1992

Physical Specifications

Display

8-line by 21-character (128 by 64 pixels) liquid crystal display.

Keypad

25 large keys including 6 Action Keys, a complete alphanumeric keypad, 4 software-defined Function Keys; membrane design with tactile feedback.

Weight

Approximately 3 lb (1.4 kg) with a Ni-Cad battery pack.

Still undecided? Let us tell you more...

The HART Communicator is the key to unlocking the power of your intelligent instruments. But configuration, calibration, and maintenance of intelligent devices in the field is only a small part of your job. You have to plan your maintenance schedule, meet the day-to-day demands of problems in the field that simply don't allow you time for preventative maintenance, and you still have another challenge—keeping accurate records of what you have done. This is the most time consuming part of your job. In fact some days you spend more time documenting what you have done than you spent doing it!

That's why Fisher-Rosemount has created Asset Management Solutions (AMS) software. This revolutionary software is more than just a database of information about your field devices, it is a tool to help you manage the process better. You can simply drag and drop information from your connected HART Communicator directly into your database. The software does the rest. You have instant access to all devices. And, with all device data at your fingertips, you can configure devices quickly, download them to your HART Communicator and be ready to head out to the field. What could be easier?

Ask your Fisher-Rosemount Sales Representative to tell you more about AMS applications and how to put them to work for you.

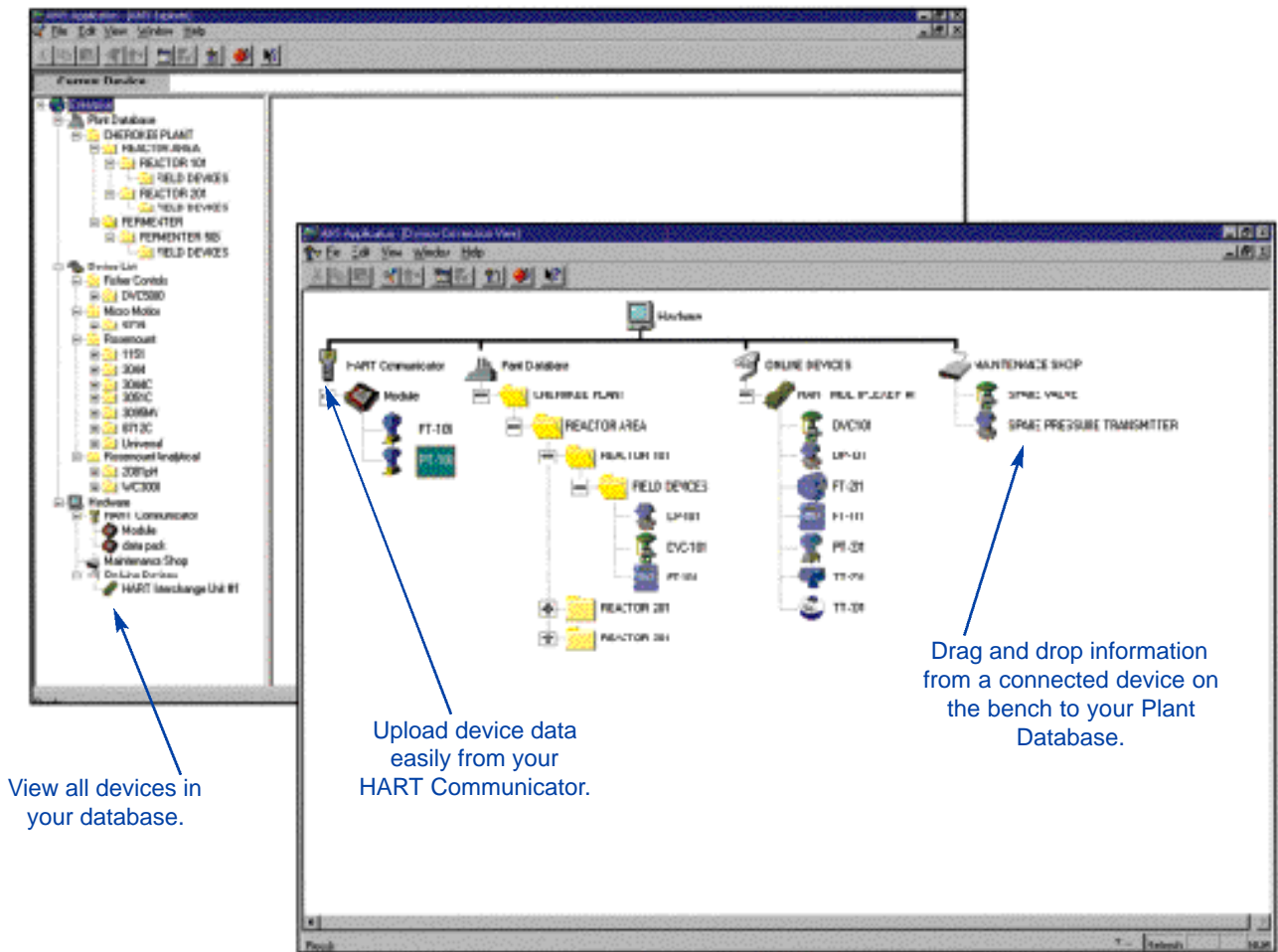

Simply drag and drop information from the HART Communicator to the Asset Management Solutions database or download data to the HART Communicator and be ready to take information to the field!

Spare Parts

	Part Number	Description
②	00275-0003-0700	Memory Module 12 MB (Standard)
②	00275-0003-0300	Memory Module 4 MB
③	00275-0006-0100	Fisher-Rosemount data pack 100
	00275-0007-0001	Recharger 220/230 VAC (U.K. plug)
	00275-0007-0002	Recharger 220/230 VAC (European plug)
	00275-0007-0003	Recharger 100/120 VAC, 50/60 Hz (U.S. plug)
⑧	00275-0093-0001	Lead Set with connectors
⑤	00275-0094-0001	Hanger (mounts on belt clip)
④	00275-0095-0001	Belt Clip with screws
⑦	00275-0096-0001	Ruggedized 250 Ohm Load Resistor
⑨	00275-0100-0001	Carrying Case
①	00275-1070-0100	AA Alkaline Battery Pack for Code I0 (No approval)
①	00275-0170-0101	AA Alkaline Battery Pack for Code I1 (CENELEC)
①	00275-0170-0102	AA Alkaline Battery Pack for Code I5 (FM)
①	00275-0170-0103	AA Alkaline Battery Pack for Code I6 (CSA)
①	00275-0171-0100	Ni-Cad Battery Pack for Code I0 (No approval)
①	00275-0171-0101	Ni-Cad Battery Pack for Code I1 (CENELEC)
①	00275-0171-0102	Ni-Cad Battery Pack for Code I5 (FM)
①	00275-0171-0103	Ni-Cad Battery Pack for Code I6 (CSA)
	00275-8026-0002	Pocket Size Manual
	00275-0013-0001	PC Communication Adapter ⁽¹⁾
	00275-8072-0001	PC Cable (DB9 to DB25) ⁽¹⁾

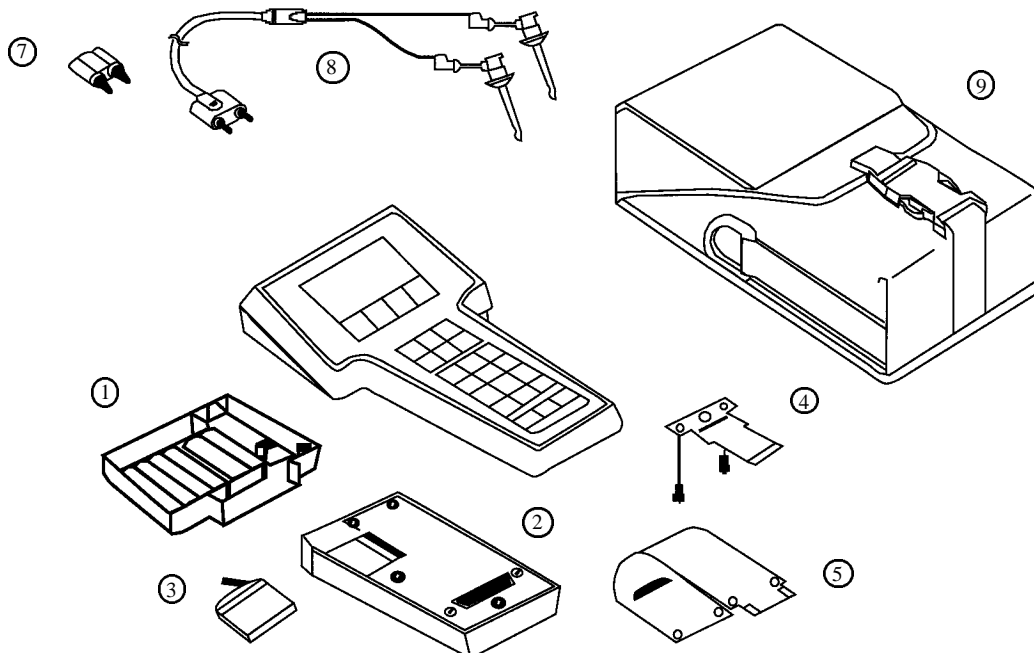

(1) Requires Asset Management Solutions (AMS) Software with 275 Interface Kit Option.

Ordering Information

Model	Product Description
275	HART Communicator ¹
Code	Battery Pack Option
D	Battery Holder for disposable AA batteries
R	Rechargeable Ni-Cad battery pack
Code	Recharger Service and Plug Type
1	110/120 VAC, 50/60 Hz (U.S. plug)
2	220/230 VAC (European plug)
3	220/230 VAC (U.K. plug)
9	None (Use this code when Battery Pack Option "D" is selected.)
Code	Language
E	English
F	French
G	German
J	Japanese
Code	Hazardous Locations Certifications
I0	No approval
I1	CENELEC - Intrinsic Safety Certification
I5	Factory Mutual (FM) - Intrinsic Safety Approval
I6	Canadian Standards Association (CSA) - Intrinsic Safety Approval
Code	Memory Module Type
B	4 MB
D	12 MB (Standard)
Code	Device Descriptor Options
00	Standard Factory Loading
Code	data pack 100 Options
D1	Shipped with (1) data pack 100 installed
D2	Shipped with (2) data pack 100s
00	Shipped without data pack 100s
Typical Model Number	275 D 9 E I0 D 00 00

¹ The Typical Model Number 275 D 9 E I0 D 00 00 includes the HART Communicator, AA battery pack with batteries, Lead Set with MINIGRABBER™ and alligator clips, carrying case, and a pocket size manual. Options include a Ni-Cad battery pack, recharger, language, certifications, and the data pack 100. If the Ni-Cad battery pack is selected, one spare battery pack per HART Communicator is recommended.

HART Communications

The HART Communicator interfaces with any HART device from any wiring termination point in a 4-20 mA loop, provided a minimum resistance of 250 ohms is present between the communicator and power supply. The HART Communicator uses the Bell 202 frequency shift keying (FSK) technique. This technique superimposes high-frequency digital communication signals on the standard 4-20 mA transmitter circuit loop. Because the net energy added to the loop is zero, communication does not disturb the 4-20 mA signal.

The contents of this publication are presented for informational purposes only, and while every effort has been made to ensure their accuracy, they are not to be construed as warranties or guarantees, express or implied, regarding the products or services described herein or their use or applicability. All sales are governed by our terms and conditions, which are available on request. We reserve the right to modify or improve the designs or specifications of our products at any time without notice.

© Fisher-Rosemount, 2001. All rights reserved. Fisher-Rosemount, and Managing The Process Better, are marks of one of the Fisher-Rosemount group of companies. All other marks are the property of their respective owners.

The HART Communicator may be protected by U.S. Pat. No. Des. 292, 401; 998, 990; other U.S. and Foreign Patents Issued and Pending.

Visit us at: www.hartcommunicator.com
www.assetweb.com

FISHER-ROSEMOUNT™
Managing The Process Better.